

SUB-418

Cinema subwoofer

Whatever design you have in mind, MAG Cinema will surely surprise you. Starting with small and professional home cinemas and up to large-scale indoor and outdoor theaters, our surround speakers come in many shapes, sizes, and performance capabilities.

Based on extensive experience of pro-audio, we have built subwoofers designed to withstand most demanding cinema soundtracks imaginable. Own design and production of low-frequency transducers and effective enclosures fit perfectly global cinema experience, which MAG Cinema speakers surely have contributed to.

Featuring large-scale subwoofers for big theaters, main subwoofer channel, smaller solution for more compact cinemas, and specific wall mountable subwoofers for modern 3D sound cinema standards – all of this is provided with MAG Cinema 7-year warranty.

The 18" high efficiency subwoofer, SUB-418 allows to cover wide range of hall sizes. Long excursion optimized drivers offer great sensitivity, and provide best SPL/power handling ratio in it's class.



DIMENSIONS

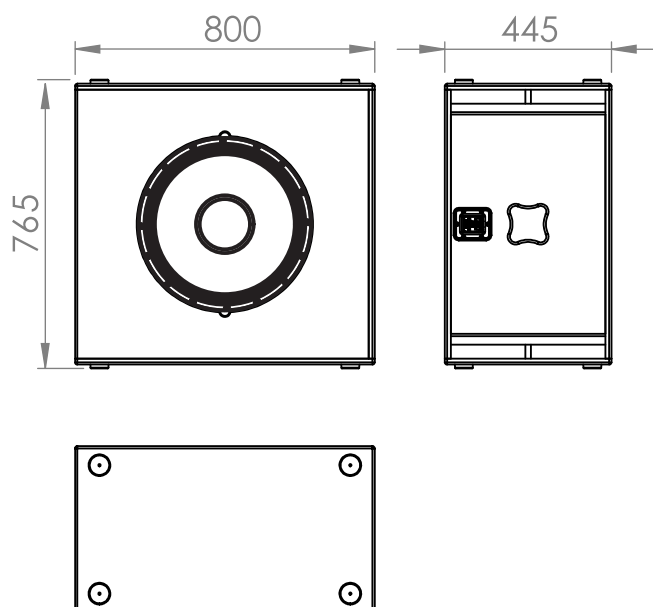

SPECIFICATIONS

Frequency response (± 3 dB)	31 - 150 Hz
Sensitivity (1W/1m) (half-space) ¹	98 dB
Max continuous SPL ²	125,7 dB
Driver	18"
Nominal impedance	4 Ohm (Sub-418-4) 8 Ohm (Sub-418-8)
Rated power ³	600 W
Connectors	Phoenix
Dimension (WxHxD)	800x765x445mm
Net weight	59,1 kg
Gross weight	63,1 kg
Enclosure materials	Plywood, MDF, wear-resistant paint
Colour	Black
¹ - dBSPL, IEC 60268-5 pink noise, 1W / 1m	
² - dBSPL RMS, IEC 60268-5 pink noise, measured on nominal power	
³ - 2 hour power test, IEC filtered noise, 6 dB crest factor	

SAFETY INSTRUCTIONS

1. Do not pour liquids on speaker system – this may cause driver cone destruction and unappealing speaker appearance. Do not allow direct sunlight on speaker cone – this will reduce its resource dramatically. For fire safety do not install speaker system near open flames or heating elements.
2. Do not use speaker system with damaged connector or speaker cable - this is an electric shock hazard and fire hazard.
3. Make sure the speaker system is firmly set up on ceiling, stage, or wall (where applicable).
4. While setting speaker system up on slope or slippery surface, make necessary arrangements to avoid its movement due to its vibration.
5. The speaker system is capable of delivering a significant sound pressure levels. To avoid permanent or temporary hearing damage, prolonged exposure to sound pressure levels exceeding 90 dB should be limited.

CONNECTIONS

Use Hi-pass filter to prevent speaker damage and distorted sound by eliminating low non-audible frequencies in input signal.

Do not exceed input powers, abovementioned in specifications, while exploiting the speaker system.

Speaker system comes with phoenix connector for connection to an amplifier.

Connection:	
Signal +	+ pin
Signal -	- pin
High pass filter	31 Hz BW24
Recommended amplifier power	600 - 1200 W on nominal impedance