

# SCR-165S

## Cinema screen speaker

Whatever design you have in mind, MAG Cinema will surely surprise you. Starting with small and professional home cinemas and up to large-scale indoor and outdoor theaters, our surround speakers come in many shapes, sizes, and performance capabilities.

Based on our own carefully designed and fine-tuned components, our surround systems provide smooth operation and optimal coverage, and are approved to be used with latest 3D sound cinema standards.

With comprehensive range of installation accessories, including fittings and brackets, MAG Cinema screen speakers are easily mounted for quick overall installation times. Provided 7-year warranty, it is a kind of equipment you can rely on for years.

Providing great value for mid-sized halls, SCR-165S is a 15" + 6" + 1" screen speaker with MF-HF section tilt/pan function for perfect sound axis positioning. Component design was calibrated for superior performance resulting in optimal amplifier usage and less total power consumption.



### DIMENSIONS

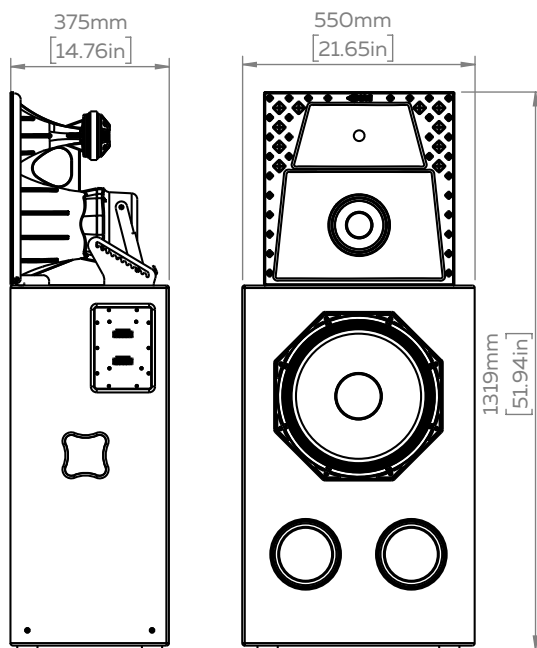

### CONNECTIONS

Use Hi-pass filter to prevent speaker damage and distorted sound by eliminating low non-audible frequencies in input signal.

Do not exceed input powers, abovementioned in specifications, while exploiting the speaker system.

Speaker system comes with Phoenix socket for connection to amplifier.

See connection plate for details on correct bi-amp and tri-amp connection.

### SAFETY INSTRUCTIONS

1. Do not pour liquids on speaker system - this may cause driver cone destruction and unappealing speaker appearance. Do not allow direct sunlight on speaker cone - this will reduce its resource dramatically. For fire safety do not install speaker system near open flames or heating elements.

2. Do not use speaker system with damaged speakON or speaker cable - this is an electric shock hazard and fire hazard.

3. Make sure the speaker system is firmly set up on ceiling, stage, or wall (where applicable).

4. While setting speaker system up on slope or slippery surface, make necessary arrangements to avoid its movement due to its vibration.

5. The speaker system is capable of delivering a significant sound pressure levels. To avoid permanent or temporary hearing damage, prolonged exposure to sound pressure levels exceeding 90 dB should be limited.

### SPECIFICATIONS

Frequency response (-6/+3)	40 - 20000 Hz
Max continuous SPL <sup>2</sup>	126 dB
Sensitivity (1W/1m half-space) <sup>1</sup>	99 dB LF 103 dB MHF biamp 103 dB MF / 109 dB HF triamp
Drivers	15" + 6" + 1"
Coverage Horizontal <sup>3</sup>	70°-90° variable
Coverage Vertical <sup>3</sup>	40°
MHF section vertical tilt angle	-4° (up) - +16° (down)
MHF section horizontal pan angle	-25° - +25°
Nominal impedance	4 Ohm LF 8 Ohm MHF biamp 8 Ohm MF / 8 Ohm HF triamp
Rated power <sup>4</sup>	500 W LF 250 W MHF biamp 200 W MF / 50 W HF triamp
Connectors	Phoenix
Recommended amplifier power	500 - 1000 W LF 250 - 500 W MHF biamp 200 - 400 W MF triamp 50 - 100 W HF triamp
Recommended high pass filter	LF 40 Hz BW24
Recommended crossover bi-amp	LF-MHF 300Hz LR24
Recommended crossover tri-amp	LF-MF 300Hz LR24 MF-HF 1000Hz LR24
Dimension (WxHxD)	550x1319x375 mm / 21,65"x51,94"x14,76"
Net weight	59,8 kg / 131,84 lbs
Gross weight	63,7 kg / 140,43 lbs
Mounting	4xM5 floor mounting
Enclosure materials	Plywood, MDF, wear-resistant paint
Colour	Black

<sup>1</sup> - dB SPL, IEC 60268-5 pink noise, 1W / 1m

<sup>2</sup> - dB SPL RMS, IEC 60268-5 pink noise, measured on nominal power

<sup>3</sup> - The HF horn has a wider dispersion in the near-field and narrower in the far field. HF horn has a 40° vertical coverage and a radiation axis aiming along the horizontal plane. At 20° up from horizontal plane speaker has a horizontal coverage of 70°. At 20° down from horizontal plane speaker has a horizontal coverage of 90°

<sup>4</sup> - 2 hour power test, IEC filtered noise, 6 dB crest factor