

H-Sub

Cinema subwoofer

It's impossible to imagine a modern cinema without thunderous deep sound. For the cinemas that long for it, MAG Cinema provides a range of high-performance, rigid and reliable cinema subwoofers.

Based on extensive experience of pro-audio, we have built subwoofers designed to withstand most demanding cinema soundtracks imaginable. Own design and production of low-frequency transducers and effective enclosures fit perfectly global cinema experience, which MAG Cinema speakers surely have contributed to.

Featuring large-scale subwoofers for big theaters, main subwoofer channel, smaller solution for more compact cinemas, and specific wall mountable subwoofers for modern 3D sound cinema standards – all of this is provided with MAG Cinema 7-year warranty.

Bringing the new edge to the cinema low frequency reinforcement, H-Sub is the innovative neodymium-based 24" subwoofer. It delivers incredible sound pressure while keeping the installation depth in check to fit into very limited behind-the-screen space.



DIMENSIONS

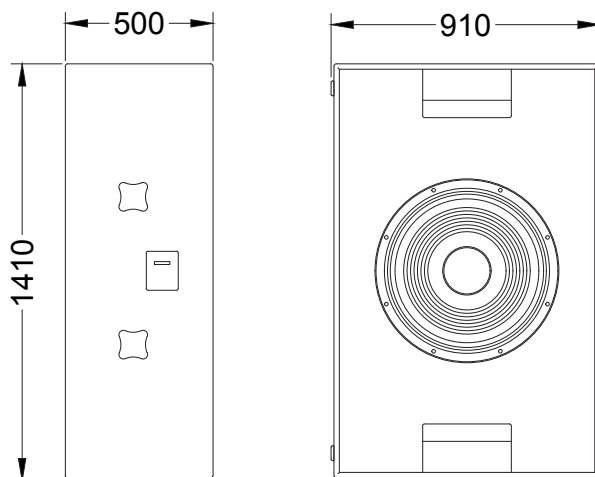

CONNECTIONS

Use Hi-pass filter to prevent speaker damage and distorted sound by eliminating low non-audible frequencies in input signal.

Do not exceed input powers, abovementioned in specifications, while exploiting the speaker system.

Speaker system comes with barrier strip screw terminal for connection to amplifier.

Connection:	
Signal +	+ Terminal
Signal -	- Terminal
High pass filter:	29 Hz BW24
Recommended amplifier power	1600 - 3200 W on nominal impedance

SPECIFICATIONS

Frequency response (± 3 dB)	29 - 140 Hz
Sensitivity (1W/1m) (half-space) ¹	99 dB
Max continuous SPL ²	131 dB
LF Transducer	24"
Impedance	4 Ohm
Rated power ³	1600 W
Connectors	Phoenix
Dimensions (WxHxD)	910x1410x500 mm
Net weight	87 kg
Shipping weight	96 kg
Enclosure materials	Plywood; wear-resistant paint

¹- dB SPL, IEC 60268-5 pink noise, 1W / 1m
²- dB SPL RMS, IEC 60268-5 pink noise, measured on nominal power
³- 2 hour power test, IEC filtered noise, 6 dB crest factor

SAFETY INSTRUCTIONS

1. Do not pour liquids on speaker system - this may cause driver cone destruction and unappealing speaker appearance. Do not allow direct sunlight on speaker cone - this will reduce its resource dramatically. For fire safety do not install speaker system near open flames or heating elements.
2. Do not use speaker system with damaged speaker cable - this is an electric shock hazard and fire hazard.
3. Make sure the speaker system is firmly set up on ceiling, stage, or wall (where applicable).
4. While setting speaker system up on slope or slippery surface, make necessary arrangements to avoid its movement due to its vibration.
5. The speaker system is capable of delivering significant sound pressure levels. To avoid permanent or temporary hearing damage, prolonged exposure to sound pressure levels exceeding 90 dB should be limited.